

HIGHER PERFORMANCE POUND FOR POUND...

AND DOLLAR FOR DOLLAR.



The International® 8600 brings a whole new level of value and performance to regional haul operations. Outstanding maneuverability and a commanding view of the road. Fuel-saving aerodynamics. Sure-footed entry/egress. Easy serviceability.

Responsive and fun to drive with bold looks inside and out, the International 8600 is uniquely qualified to deliver value to your bottom line while helping you attract and retain the best drivers.



THE BRILLIANCE OF COMMON SENSE.™



1 Breakaway mirror design withstands up to a 9-mph impact, reducing progressive door damage by as much as \$900-\$1,200. (Optional bright-finish mirrors shown.)

3 Self-diagnostic International Diamond Logic Electrical System and color-coded, continually numbered air lines allow for quicker troubleshooting and repairs. Smart frame routing and clipping reduce chafing of air lines and electrical harnesses.

4 Best-in-class HVAC system increases airflow. A self-diagnostic protection system shuts down the A/C compressor in the event of a refrigerant leak to prevent further damage – a potential repair savings of up to \$250.

2 Boldly styled, sloped hood offers impressive forward visibility while reducing aerodynamic drag for maximum fuel economy. Three-piece design allows individual sections to be removed and replaced, making repairs as much as \$700-\$3,000 less than competitive hoods.

POTENTIAL ADDED VALUE BASED ON 200,000 OWNERSHIP MILES (321,869 KM)

	FEATURE	ADDED VALUE
1	Breakaway mirrors	\$900-\$1,200
2	Three-piece hood (front corner replacement)	\$700-\$3,000
3	International Diamond Logic™ Electrical System	\$500
4	HVAC system self-diagnostics	\$250
	POTENTIAL TOTAL	\$2,350-\$4,950



- Frame-mounted vertical muffler reduces interior noise and increases cab structural integrity.
- Three-step E-Coat prime/base coat/urethane clear coat paint process for the cab and hood resists corrosion, minor scratches and fading. Backed by a 5-year limited cab warranty.
- 2,038-square-inch (13,149 sq cm) windshield offers a commanding view of the road with outstanding peripheral vision. Swept-back angle and curved design help deflect road debris and minimize glass damage.
- Chrome grille instills driver pride and projects a positive image of your company. Removable grille can be replaced independently in less than 15 minutes.
- Aerodynamic composite headlight cover protects standard halogen headlights from damage. No tools required to replace bulbs.
- One-piece aerodynamic bumper with flexible end caps protects fenders from minor impact without added weight and repair costs associated with multipiece designs.
- 120,000-psi (827,400 kPa) frame rail is stronger than most competitive frames of equal size – without reinforcements or inserts. The bottom line: bigger payloads and a more durable frame system.
- Standard huck-bolted frame fasteners provide 50-60 times greater clamping load than threaded fasteners, eliminating the need to retorque frame bolts.
- Steel D-shaped 80- or 100-gallon (303 L or 379 L) fuel tanks won't roll in cradle.
- Slip-resistant offset steps and grab handles provide easy three-point entry/egress.
- High-pressure power steering pump reduces driver fatigue during tight maneuvers.
- Standard cab air suspension extends cab life and minimizes cab vibration for a smoother ride.
- Powder-coated paint resists chips and scratches. Standard on bumper, mirror arms/housings, fuel tanks, steps and air tanks; optional on wheels.
- 46" (117 cm) set-back wide-track axle and wheel cut up to 50° deliver outstanding maneuverability and weight distribution.
- Lightweight parabolic taperleaf front springs deliver improved ride and handling. Rubber spring pin bushings are maintenance-free.
- Splash shields tilt with the hood for easy under-hood access and routine maintenance checks. Service fill points accessed from ground level.

International® 8600 Tractor Popular Feature Options

8600 SBA 6x4

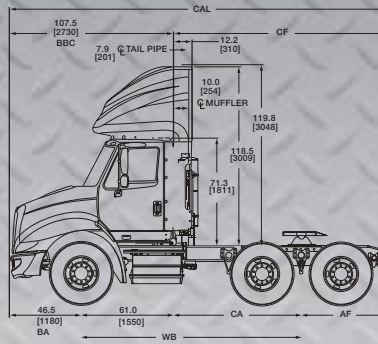

Engines

Cummins ISM: 280, 310*, 330, 350, 370 hp Ratings
 Caterpillar C-10: 305-350 hp Ratings
 Caterpillar C-12: 355-445 hp Ratings

Transmissions

Fuller 10*, 13-Speed Manual with Air Shift
 Eaton Fuller AutoShift 10-Speed
 Eaton Fuller Lightning Series 10-Speed

Axle, Front, I-Beam Type

Dana Spicer Wide-Track 10,000, 12,000*, 13,200-lb Capacity
 Dana Spicer Standard Track 12,000-lb Capacity
 Meritor Wide-Track 10,000, 12,000, 13,200-lb Capacity

Axle, Rear, Tandem (6x4 only)

Dana Spicer Single-Reduction 40,000-lb Capacity* with or without Lube Pump
 Dana Spicer Single-Reduction 40,000-lb Capacity with Driver-Controlled Locking Differential
 Meritor Single-Reduction 40,000-lb Capacity with or without Lube Pump
 Meritor Single-Reduction 40,000-lb Capacity with Driver-Controlled Main Locking Differential

Axle, Rear, Single (4x2 only)

Dana Spicer, Single-Reduction 23,000-lb Capacity*
 Dana Spicer, Single-Reduction, 23,000-lb Capacity with Driver-Controlled Locking Differential
 Meritor, Single-Reduction, 23,000-lb Capacity
 Meritor, Single-Reduction, 23,000-lb Capacity with Driver-Controlled Locking Differential

Suspension, Rear, Single

Spring, Vari-Rate* 20,000, 23,000-lb Capacity
 Torque Rod Type, Multi-Leaf 20,000, 23,000-lb Capacity
 Spring, Vari-Rate with Auxiliary Rubber Springs 20,000, 23,000-lb Capacity

Suspension, Rear, Tandem

International® Four-Spring Suspension 40,000-lb Capacity*
 International® Ride-Optimized Suspension (IROS) 40,000-lb Capacity
 52", 55", 60" Axle Spacing

Suspension, Front Springs

10,000, 12,000*, 13,200-lb Taperleaf

ABS

Bendix 4-Channel Antilock Brake System*
 Bendix 4-Channel Antilock Brake System with Automatic Traction Control
 Meritor-Wabco 4-Channel
 Meritor-Wabco 4-Channel with Automatic Traction Control

Fuel Tanks

Single 80-gallon*, 23" Steel* and Non-Polished Aluminum
 Dual 80-gallon, 23" Steel or Polished and Non-Polished Aluminum
 Single 100-gallon, 23" Steel and Non-Polished Aluminum
 Dual 100-gallon, 23" Steel or Polished and Non-Polished Aluminum

Tires

Goodyear*, Michelin

Fifth Wheel

Fontaine* Stationary or Air Slide 12", 24" Sliders (Cast or Stamped) or 24" Manual Slide

Wheels - Front & Rear

Disc: 22.5"* , 24.5" Painted*, Polished and Non-Polished Aluminum
 Dual Disc: 22.5" , 24.5" Painted, Polished and Non-Polished Aluminum

Cab

Extended Cab with Optional 26" Bunk
 Extended Cab with Storage

Aerodynamic

Roof Air Deflector (Pod, Fixed, Collapsible) and Cab Side Extenders

Deluxe and Premium Trim Levels

*Standard Equipment

Specifications are subject to change without notice.

For more information on the International® 8600, see your International® dealer or visit our web site at www.InternationalDelivers.com.



THE BRILLIANCE OF COMMON SENSE.™

Specifications, descriptions and illustrative material in this literature are as accurate as known at time of publication, but are subject to change without notice. Illustrations may include optional equipment and accessories, and may not include all standard equipment. THE BRILLIANCE OF COMMON SENSE. and Diamond Logic are trademarks of International Truck and Engine Corporation. International and the International Diamond logo are registered trademarks of International Truck and Engine Corporation.